

Matching MOSFET Drivers to MOSFETs

*Author: Jamie Dunn
Microchip Technology Inc.*

INTRODUCTION

There are many MOSFET technologies and silicon processes in existence today, with new advances being made every day. To make a generalized statement about matching a MOSFET driver to a MOSFET based on voltage/current ratings or die sizes is very difficult, if not impossible.

As with any design decision, there are multiple variables involved when selecting the proper MOSFET driver for the MOSFET being used in your design. Parameters such as input-to-output propagation delay, quiescent current, latch-up immunity and driver current rating must all be taken into account. Power dissipation of the driver will also effect your packaging decision and driver selection.

This Application Note discusses the details of MOSFET driver power dissipation in relation to MOSFET gate charge and operating frequency. It also discusses how to match MOSFET driver current drive capability and MOSFET gate charge based on desired turn-on and turn-off times of the MOSFET.

Microchip offers many variations of MOSFET drivers in various packages, which allows the designer to select the optimal MOSFET driver for the MOSFET(s) being used in their application.

POWER DISSIPATION IN A MOSFET DRIVER

Charging and discharging the gate of a MOSFET requires the same amount of energy, regardless of how fast or slow (rise and fall of gate voltage) it occurs. Therefore, the current drive capability of the MOSFET driver does not effect the power dissipation in the driver due to the capacitive load of the MOSFET gate.

There are three elements of power dissipation in a MOSFET driver:

1. Power dissipation due to the charging and discharging of the gate capacitance of the MOSFET.

EQUATION 1:

$$P_C = C_G \times V_{DD}^2 \times F$$

Where:

C_G = MOSFET Gate Capacitance
 V_{DD} = Supply Voltage of MOSFET Driver (V)
 F = Switching Frequency

2. Power dissipation due to quiescent current draw of the MOSFET driver.

EQUATION 2:

$$P_Q = (I_{QH} \times D + I_{QL} \times (1 - D)) \times V_{DD}$$

Where:

I_{QH} = Quiescent current of the driver with the input in the high state
 D = Duty cycle of the switching waveform
 I_{QL} = Quiescent current of the driver with the input in the low state

3. Power dissipation due to cross-conduction (shoot-through) current in the MOSFET driver.

EQUATION 3:

$$P_S = CC \times F \times V_{DD}$$

Where:

CC = Crossover constant (A*sec)

As deduced from the equations above, only one of the three elements of power dissipation is due to the charging and discharging of the MOSFET gate capacitance. This portion of the power dissipation is typically the highest, especially at lower switching frequencies.

In order to calculate a value for Equation 1, the gate capacitance of the MOSFET is required. The gate capacitance of a MOSFET is comprised of two capacitances: the gate-to-source capacitance and the gate-to-drain capacitance (Miller Capacitance). A common mistake is to use the Input Capacitance rating of the MOSFET (C_{ISS}) as the total gate capacitance of the MOSFET. The proper method for determining gate capacitance is to look at the **Total Gate Charge** (Q_G) in the MOSFET data sheet. This information is typically shown in the Electrical Characteristics table and as a typical characteristics curve in any MOSFET data sheet.

AN799

Table 1 shows a typical example of the data sheet representation of gate charge for a 500V, 14A, N-channel MOSFET. Note that the values given in the data sheet table have conditions associated with them: gate voltage and drain voltage. These conditions effect the

gate charge value. Figure 1 shows the gate charge typical characteristic curve for the same MOSFET as it varies with gate voltage and drain voltage. Make sure the gate charge value you use for calculating power dissipation fits the conditions of your application.

TABLE 1: DATA SHEET REPRESENTATION FOR GATE CHARGE

Pin Name	Parameter	Min.	Typ.	Max.	Units	Test Conditions
Q _G	Total Gate Charge	—	—	150	nC	I _D = 14A V _{DS} = 400V V _{GS} = 10V
Q _{GS}	Gate-to-Source Charge	—	—	20		
Q _{GD}	Gate-to-Drain Charge	—	—	80		
C _{ISS}	Input Capacitance	—	2600	—	pF	V _{GS} = 0V V _{DS} = 25V f = 1.0 MHz
C _{OSS}	Output Capacitance	—	720	—		
C _{RSS}	Reverse Transfer Capacitance	—	340	—		

Taking a typical value from the graph in Figure 1 for V_{GS} = 10V, we get a total gate charge of 98 nC (V_{DS} = 400V). Using the relationship Q = C * V, we get a gate capacitance value of 9.8 nF, which is significantly higher than the 2.6 nF input capacitance that is specified in Table 1. This illustrates the fact that when a calculation calls for a gate capacitance value, the total gate capacitance value should be derived from the total gate charge value.

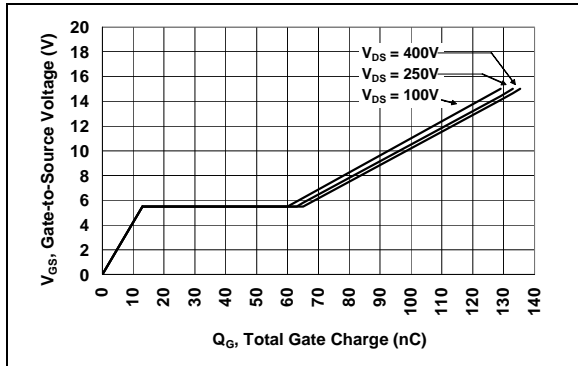

FIGURE 1: Total Gate Charge vs. Gate-to-Source Voltage (500V, 14A, N-channel MOSFET).

When using maximum values for gate charge from the Electrical Characteristics table for worst-case design, the values must be adjusted for the drain-to-source and gate-to-source voltages in your design.

Using the MOSFET information presented in Table 1 and Figure 1 as an example, the power dissipation in a MOSFET driver due to the charging and discharging of the gate capacitance of this MOSFET with a V_{GS} of 12V, a switching frequency of F = 250 kHz and a drain-to-source voltage of 400V would be:

$$P_C = C_G \times V^2 \times F$$

$$P_C = 9.5 \times 10^{-9} \times (12)^2 \times 250 \times 10^3$$

$$P_C = 342mW$$

The value for C_G is arrived at by using the graph in Figure 1 and finding the value for Q_G at 12V. Q_G is then divided by 12V to get the C_G value. Knowing that Q_G is equal to C_G * V_G, the equation for P_C could be rewritten as:

$$P_C = Q_G \times V \times F$$

A note of importance is that the voltage in this equation is squared. Therefore, a reduction in the gate drive voltage can result in a significant reduction in power loss in the driver. For some MOSFETs, driving the gate voltage above 8V to 10V does not result in any further decrease in MOSFET resistance (R_{DS-ON}). Using the same MOSFET as above as an example, a 10V gate drive results in the following power dissipation:

$$P_C = Q_G \times V \times F$$

$$P_C = 98 \times 10^{-9} \times 10 \times 250 \times 10^3$$

$$P_C = 245mW$$

The 16% reduction in gate voltage (going from 12V to 10V) resulted in a 28% reduction in power dissipation due to gate drive. Further savings will also be seen in the cross-conduction losses due to gate drive voltage reduction.

Equation 3 represents the power dissipation due to MOSFET driver cross-conduction, or what is commonly referred to as shoot-through. This is a result of the P-channel and N-channel FETs in the output drive stage being on at the same time as they transition between the on and off states.

Cross-conduction characteristics are shown in the MOSFET driver data sheet as a typical characteristic curve and as “Crossover Energy vs. Supply Voltage”. An example of this is shown in Figure 2.

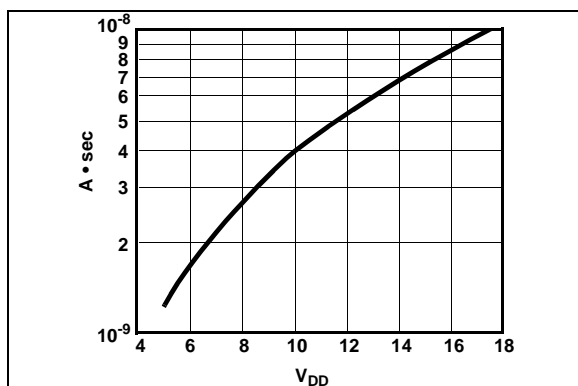

FIGURE 2: Crossover Energy vs. Supply Voltage.

The units for the crossover constant are typically shown as Amp-Seconds (A*sec). Multiplying this number by the frequency of operation yields a value for average current. Figure 2 illustrates a point that was discussed earlier. Namely, as bias voltage increases, the crossover constant increases and, consequently, the power dissipation in the driver (due to cross-conduction) increases. Therefore, a decrease in driver voltage will result in a decrease in driver power dissipation.

One thing to make note of is that when using a dual driver, the crossover constant is usually shown for both portions of the driver operating. If only one portion of the driver is being used, or the two portions of the driver are operating at different frequencies, be sure to use only half the value for each portion of the driver.

Using the information illustrated in Figure 2 as an example, we will assume it is for a single-output driver operating with a V_{DD} of 12V, at a frequency of 250 kHz. Based on the graph, the crossover constant is found to be 5.2*10⁻⁹.

$$P_S = CC \times F \times V$$

$$P_S = 5.2 \times 10^{-9} \times 250 \times 10^3 \times 12$$

$$P_S = 15.6mW$$

For this driver, operating at this voltage and frequency, the power dissipation is relatively insignificant. Typically, as the current drive capability of the MOSFET driver increases, the losses due to shoot-through current will also increase. These losses can be significant and need to be taken into account when selecting a package for the MOSFET driver.

Microchip offers surface-mount and pin through-hole packages, ranging from 8-pin MSOPs to 8-pin DFNs to 5-pin TO-220s, allowing for the selection of the package that is most appropriate for your application.

DIE SIZE EFFECT ON GATE CAPACITANCE

As can be expected, the larger the die size of the MOSFET, the larger the effective gate charge. For an illustration of this, browse through any manufacturer's data book. By relating die size to total gate charge, you will find that, as die size increases, the total gate charge will also increase. As advances are made in silicon technology, new MOSFETs are produced that may have the same die size as an older device, but with a lower total gate charge. However, MOSFETs within the same silicon technology still follow the same general rule that as die size goes up, so does the gate charge requirement.

Die sizes will often be referred to in Hex size. Table 2 below gives some typical die sizes and total gate capacitance values for various MOSFET size Hex ratings.

TABLE 2: HEX RATINGS AND TYPICAL GATE CAPACITANCE FOR MOSFET DIE SIZE

MOSFET Size	Die Size (mm)	Total C of MOSFET (pF)
Hex 0	0.89 X 1.09	400
Hex 1	1.75 x 2.41	750
Hex 2	3.40 x 2.21	1500
Hex 3	4.44 x 2.79	3000
Hex 4	7.04 x 4.32	6000
Hex 5	6.45 x 6.45	12000
Hex 6	283 x 348 mil	15000
Hex 7	283 x 348 mil	16000
Parallel Modules	Various	Up to 48,000

Many suppliers today have also come out with “low gate charge” versions of MOSFETs that allow for faster switching times and lower gate charge losses. These devices allow applications to operate at higher speeds, with lower switching losses in the power MOSFET, as well as lower gate charge losses in the MOSFET driver.

PEAK CURRENT DRIVE REQUIREMENTS

The elements of the MOSFET driver that have been discussed so far have been related to the power dissipation of the MOSFET driver from both internal and external sources. Being able to calculate the power losses of the MOSFET driver will assist in being able to select the correct package for the driver and allow for junction temperatures to be calculated.

Matching the MOSFET driver to the MOSFET in the application will primarily be based on how fast the application requires the power MOSFET to be turned on and off (rise and fall time of the gate voltage). The optimum rise/fall time in any application is based on many requirements, such as EMI (conducted and radiated), switching losses, lead/circuit inductance, switching frequency, etc.

The speed at which a MOSFET can be turned on and off is related to how fast the gate capacitance of the MOSFET can be charged and discharged. The relationship between gate capacitance, turn-on/turn-off time and the MOSFET driver current rating can be written as:

$$dT = \frac{[dV \times C]}{I}$$

Where:

- dT = turn-on/turn-off time
- dV = gate voltage
- C = gate capacitance (from gate charge value)
- I = peak drive current (for the given voltage value)

Knowing the relationship given earlier for gate charge is:

$$Q = C \times V$$

The above equation can be rewritten as:

$$dT = \frac{Q}{I}$$

Where:

- Q = total gate charge

The relationship shown in the equations above assumes that a constant current source is being used for the current (I). By using the peak drive current of the MOSFET driver, some error will be incurred.

MOSFET drivers are rated by the driver output peak current drive capability. This peak current drive capability is generally given for one of two conditions. Either the MOSFET driver output is shorted to ground or the MOSFET driver output is at a particular voltage value (usually 4V, as this is the gate threshold voltage at which the MOSFET begins to turn on and the Miller effect comes into play). The peak current rating is also generally stated for the maximum bias voltage of the part. This means that if the MOSFET driver is being used with a lower bias voltage, the peak current drive capability of the MOSFET driver will be lower.

Design Example:

Using the following design parameters, the MOSFET driver peak output current rating will be found:

- MOSFET gate charge = 20 nC (Q)
- MOSFET gate voltage = 12V (dV)
- Turn-on/turn-off time = 40 ns (dT)

Using the equation referenced earlier:

$$dT = \frac{Q}{I}$$

$$I = \frac{Q}{dT}$$

$$I = \frac{20nC}{40ns}$$

$$I = 0.5A$$

The equation has produced a peak drive current requirement of 0.5A. However, the gate drive voltage in the design parameters is 12V, and this must be taken into account when selecting the appropriate driver. For instance, if the driver you are selecting is rated for 0.5A at 18V, the peak output current at 12V will be less than 0.5A. For this reason, a driver with a 1.0A peak output current at 18V would be chosen for this particular application.

Any external resistance between the MOSFET driver output and the gate of the power MOSFET will also need to be taken into account, as this will reduce the peak charging current supplied to the gate capacitance. This drive configuration is shown in Figure 4.

TYPICAL MOSFET DRIVER GATE DRIVE CONFIGURATIONS

There are many circuit configurations that MOSFET drivers can be used in. Often times, due to the high peak currents, fast rise/fall times of the drive voltages and inductance in long board traces, additional clamp circuitry is required. Figures 3 through 6 show typical gate drive circuit configurations that are often used.

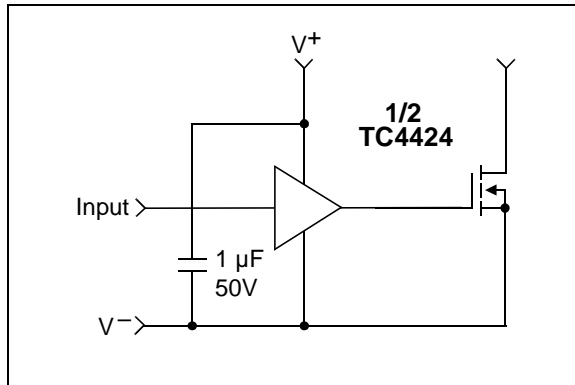

FIGURE 3: Typical MOSFET driver circuit.

The most ideal MOSFET driver circuit is shown in Figure 3. This configuration is often used in boost, fly-back and single switch forward power supply switching topologies. With proper layout techniques and appropriate bias voltage bypass capacitors, very good rise and fall times of the MOSFET gate voltage can be achieved. In addition to having local bypass capacitance on the bias voltage, the grounding of the MOSFET driver is also important.

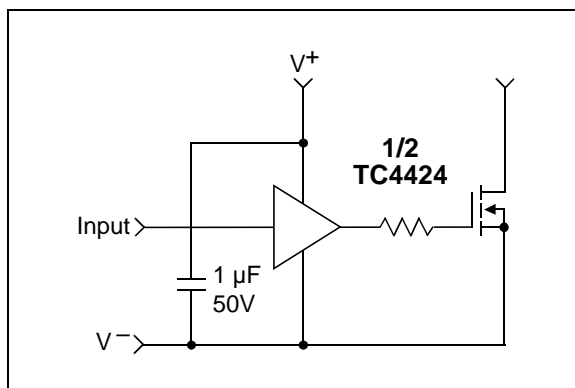

FIGURE 4: Use of a resistor to limit peak current.

In many gate drive applications, it may be necessary to limit the peak gate drive current in order to slow down the rise of the gate voltage. This is usually done to lower the EMI noise generated by fast slew rates of the MOSFET drain voltage. Slowing the rise and fall time of the MOSFET gate voltage can be accomplished by either changing to a MOSFET driver that has a lower peak current rating or by adding a series gate drive resistor, as shown in Figure 4.

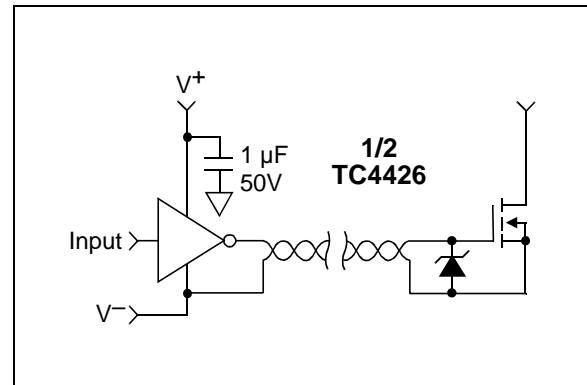

FIGURE 5: Use of zener diode to clamp voltage on long board traces.

In applications where the MOSFET driver is not placed close to the MOSFET it is driving, there will be inductance between the output of the driver and the gate of the MOSFET. This can result in the gate voltage of the MOSFET ringing above V_{DD} and below ground. If the peak voltage exceeds the maximum-rated gate voltage of the MOSFET, the MOSFET can be damaged and, thus, lead to failure. This voltage can be clamped by adding a zener diode from the gate to the source of the MOSFET, as is shown in Figure 5. When possible, the board trace length between the MOSFET driver and the MOSFET should be made as short as possible to limit this inductive ringing effect. Inductance between the driver output and gate of the MOSFET can also effect the MOSFET driver's ability to hold the gate of the MOSFET low during a transient condition.

AN799

Figure 6 shows two different gate drive configurations using gate drive transformers. Gate drive transformers can be used in both high- and low-voltage applications where an isolation boundary between the control circuitry and the power MOSFET is needed for either safety regulations or for a situation in which a high-side floating gate drive is required.

Circuits A and B in Figure 6 show a gate drive transformer being used in a single-switch forward application. The resistor and capacitor that are in series with the MOSFET driver output and gate drive transformer are used to balance the volt-time of the gate drive transformer. Because the volt-time of the gate drive transformer must be balanced (as is the case with any transformer), a negative gate-to-source voltage is also applied to the gate of the power MOSFET during the off time of the switching cycle. This can often cause switch-

ing time delays at turn-on. If this is an undesired effect, the circuit configuration in B can be used. This circuit uses the negative gate drive voltage to turn on the additional small-signal FET that shorts the gate-to-source node of the main power MOSFET in order to turn it off and keep the gate voltage at 0V. The drive configurations shown in A and B can be used for a two-switch forward topology as well.

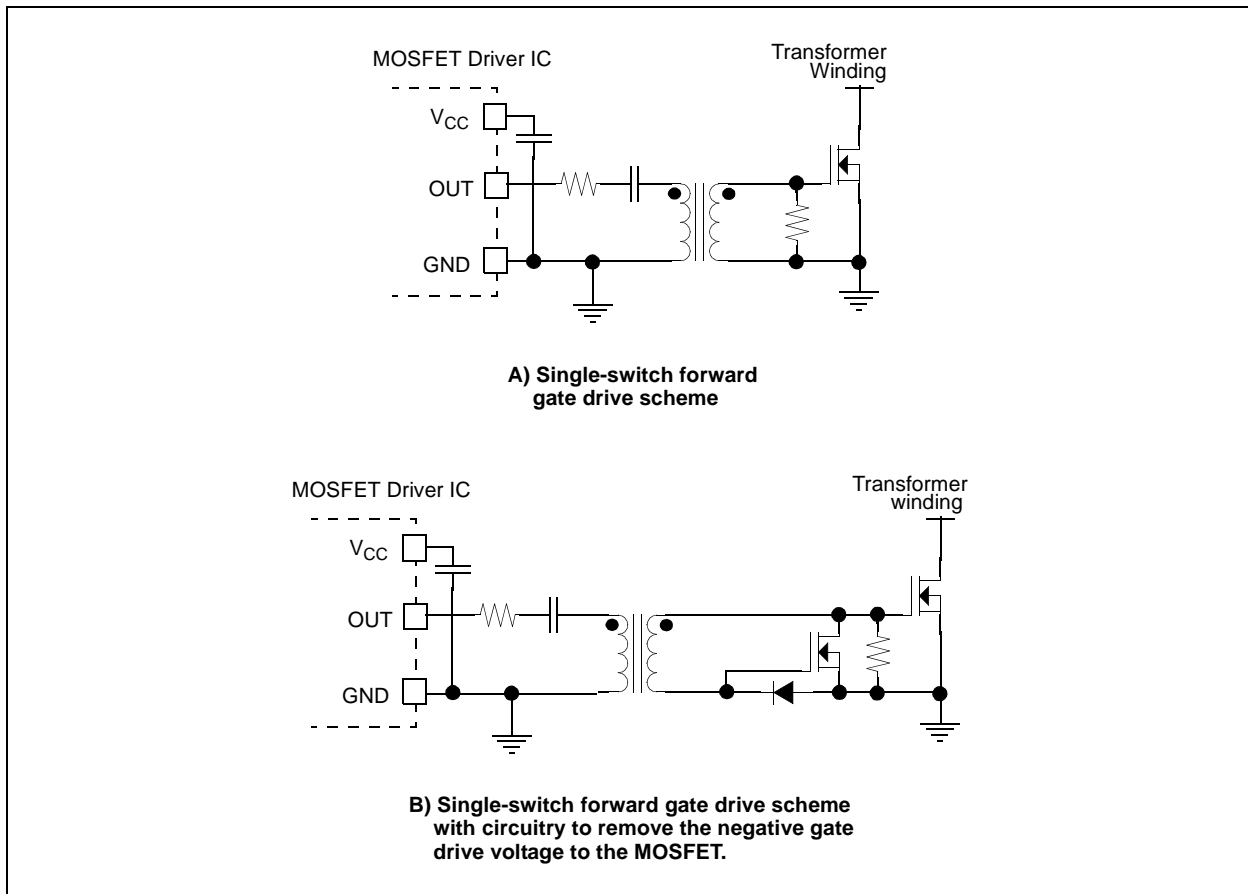

FIGURE 6: Gate Drive Transformer Applications.

MICROCHIP MOSFET DRIVER FAMILIES

Microchip offers several MOSFET driver families. These are:

- TC426\27\28** (Dual Output 1.5A)
- TC1410\11\12\13** (Single Output 0.5A to 3.0A)
- TC1426\27\28** (Dual Output 1.5A)
- TC4426\27\28** (Dual Output 1.5A)
- TC4426A\27A\28A** (Dual Output 1.5A)
- TC4403** (Split Output 1.5A)
- TC4404\05** (Dual Output 1.5A)
- TC4420\29** (Single Output 6.0A)
- TC4421\22** (Single Output 9.0A)
- TC4431\32** (Single Output 1.5A, 30V)
- TC4467\68\69** (Quad Output 1.2A)
- TC4626\27** (Single Output 1.5A)

The TC426 was the world's first CMOS MOSFET driver. It was a dual-output device capable of up to 1.5A peak currents at 18V. This 1.5A driver also came in two other versions, the dual non-inverting TC427 driver and one inverting plus one non-inverting in the TC428 driver.

The TC4426 family is the second generation of the TC426 family that, through improved processing and design, has less propagation delay and draws half the power of the first generation. These improvements have been incorporated into all drivers with four numeric digits in the part number.

Another important improvement in the second-generation families is their ability to have the input signal operate below the negative rail (ground) by as much as 5V. This parameter is very useful in systems where the control circuit ground is not closely tied to the power or source ground of the MOSFET. These two grounds often move relative to one another.

The TC4426A family of drivers incorporates all of the improvements of the TC4426 family, in addition to having matched propagational delay times. With matched propagational delay times and matched rise and fall times, this family of drivers is an ideal choice when duty cycle integrity is important.

The TC1426\27\28 family is a special, low-cost version of the TC426\27\28 family that does not have the below-rail protection on the input. It is a good choice for large-volume OEMs.

Following the same part numbering pattern as the 1.5A TC426\27\28 family, the TC4423\24\25 family of dual drivers has a 3A output capacity. The TC4424 is a dual non-inverting driver and the TC4425 is one inverting plus one non-inverting driver.

The TC4429 is a single inverting driver (like its predecessor the TC429), while the TC4420 is non-inverting. This family has a 6A drive capability at 18V. The TC4429 can slew a 10,000 pF load at 18V in 65 nsec, typically.

The TC4421 (inverting) and TC4422 (non-inverting) are a family of 9A, single-output MOSFET drivers that are pin-compatible with the TC4420/29 6A MOSFET drivers. This provides a nice migration path for those applications that may need more gate drive current capability than the 6A family can deliver. The TC1410(N), TC1411(N), TC1412(N), TC1413(N), TC4420/29 and TC4421/22 are all single-output drivers that are pin-compatible with each other.

Table 3 on the following page shows the performance of the various drivers under production test methods. The characteristics of those drivers are detailed in their individual data sheets. This table is intended only as a guide for comparing specifications.

AN799

The following families of power drivers are made with a CMOS process to interface between low-level control functions and high-power switching devices, particularly power MOSFETs. The devices are also an optimum choice for capacitive drivers where 1.2A thru 9A may be switched. Both inverting and non-inverting outputs are available, as well as dual-input logic gates.

Microchip offers additional MOSFET drivers that are not listed in Table 3. For a complete listing of Microchip's 38 MOSFET driver product offerings, please visit our web site at www.microchip.com.

TABLE 3: SELECTING MOSFET DRIVERS

Device No.	Peak Drive Current (A)	Number of Outputs and Type		Gate Capacitance (pF)	Rise Time @ Rated Load (nsec)	Fall Time @ Rated Load (nsec)	Rising Edge Prop. Delay (nsec)	Falling Edge Prop. Delay (nsec)	Input Protected to 5V Below Gnd Rail
		Inverting	Non-Inverting						
TC1426	1.2	Dual	—	1000	35	25	75	75	No
TC1427	1.2	—	Dual	1000	35	25	75	75	No
TC1428	1.2	Single	Single	1000	35	25	75	75	No
TC4426	1.5	Dual	—	1000	19	19	20	40	Yes
TC4427	1.5	—	Dual	1000	19	19	20	40	Yes
TC4428	1.5	Single	Single	1000	19	19	20	40	Yes
TC4426A	1.5	Dual	—	1000	25	25	30	30	Yes
TC4427A	1.5	—	Dual	1000	25	25	30	30	Yes
TC4428A	1.5	Single	Single	1000	25	25	30	30	Yes
TC4423	3.0	Dual	—	1800	23	25	33	38	Yes
TC4424	3.0	—	Dual	1800	23	25	33	38	Yes
TC4425	3.0	Single	Single	1800	23	25	33	38	Yes
TC4420	6.0	—	Single	2500	25	25	55	55	Yes
TC4429	6.0	Single	—	2500	25	25	55	55	Yes
TC4421	9.0	Single	—	10,000	60	60	30	33	Yes
TC4422	9.0	—	Single	10,000	60	60	30	33	Yes
TC4467	1.2	Quad NAND		470	15	15	40	40	Yes
TC4468	1.2	Quad AND		470	15	15	40	40	Yes
TC4469	1.2	Quad AND/INV		470	15	15	40	40	Yes

CONCLUSION

There are many parameters to consider when matching the appropriate MOSFET driver to the MOSFET in your application. However, by following the steps laid out in this Application Note, the proper selection can be made. Table 3 is intended to be used as a general guide to help in narrowing-down the search.

As with any electronic device, no one device is appropriate for every application, which is why Microchip Technology supplies a variety of MOSFET driver current ratings, output drive polarities and input logic configurations.

Note the following details of the code protection feature on Microchip devices:

- Microchip products meet the specification contained in their particular Microchip Data Sheet.
- Microchip believes that its family of products is one of the most secure families of its kind on the market today, when used in the intended manner and under normal conditions.
- There are dishonest and possibly illegal methods used to breach the code protection feature. All of these methods, to our knowledge, require using the Microchip products in a manner outside the operating specifications contained in Microchip's Data Sheets. Most likely, the person doing so is engaged in theft of intellectual property.
- Microchip is willing to work with the customer who is concerned about the integrity of their code.
- Neither Microchip nor any other semiconductor manufacturer can guarantee the security of their code. Code protection does not mean that we are guaranteeing the product as "unbreakable."

Code protection is constantly evolving. We at Microchip are committed to continuously improving the code protection features of our products. Attempts to break Microchip's code protection feature may be a violation of the Digital Millennium Copyright Act. If such acts allow unauthorized access to your software or other copyrighted work, you may have a right to sue for relief under that Act.

Information contained in this publication regarding device applications and the like is intended through suggestion only and may be superseded by updates. It is your responsibility to ensure that your application meets with your specifications. No representation or warranty is given and no liability is assumed by Microchip Technology Incorporated with respect to the accuracy or use of such information, or infringement of patents or other intellectual property rights arising from such use or otherwise. Use of Microchip's products as critical components in life support systems is not authorized except with express written approval by Microchip. No licenses are conveyed, implicitly or otherwise, under any intellectual property rights.

Trademarks

The Microchip name and logo, the Microchip logo, Accuron, dsPIC, KEELOQ, microID, MPLAB, PIC, PICmicro, PICSTART, PRO MATE, PowerSmart, rfPIC, and SmartShunt are registered trademarks of Microchip Technology Incorporated in the U.S.A. and other countries.

AmpLab, FilterLab, MXDEV, MXLAB, PICMASTER, SEEVAL, SmartSensor and The Embedded Control Solutions Company are registered trademarks of Microchip Technology Incorporated in the U.S.A.

Analog-for-the-Digital Age, Application Maestro, dsPICDEM, dsPICDEM.net, dsPICworks, ECAN, ECONOMONITOR, FanSense, FlexROM, fuzzyLAB, In-Circuit Serial Programming, ICSP, ICEPIC, Migratable Memory, MPASM, MPLIB, MPLINK, MPSIM, PICkit, PICDEM, PICDEM.net, PICLAB, PICtail, PowerCal, PowerInfo, PowerMate, PowerTool, rLAB, rfPICDEM, Select Mode, Smart Serial, SmartTel and Total Endurance are trademarks of Microchip Technology Incorporated in the U.S.A. and other countries.

SQTP is a service mark of Microchip Technology Incorporated in the U.S.A.

All other trademarks mentioned herein are property of their respective companies.

© 2004, Microchip Technology Incorporated, Printed in the U.S.A., All Rights Reserved.

 Printed on recycled paper.

**QUALITY MANAGEMENT SYSTEM
CERTIFIED BY DNV
== ISO/TS 16949:2002 ==**

Microchip received ISO/TS-16949:2002 quality system certification for its worldwide headquarters, design and wafer fabrication facilities in Chandler and Tempe, Arizona and Mountain View, California in October 2003. The Company's quality system processes and procedures are for its PICmicro® 8-bit MCUs, KEELOQ® code hopping devices, Serial EEPROMs, microperipherals, nonvolatile memory and analog products. In addition, Microchip's quality system for the design and manufacture of development systems is ISO 9001:2000 certified.



WORLDWIDE SALES AND SERVICE

AMERICAS

Corporate Office

2355 West Chandler Blvd.
Chandler, AZ 85224-6199
Tel: 480-792-7200
Fax: 480-792-7277
Technical Support: 480-792-7627
Web Address: www.microchip.com

Atlanta

3780 Mansell Road, Suite 130
Alpharetta, GA 30022
Tel: 770-640-0034
Fax: 770-640-0307

Boston

2 Lan Drive, Suite 120
Westford, MA 01886
Tel: 978-692-3848
Fax: 978-692-3821

Chicago

333 Pierce Road, Suite 180
Itasca, IL 60143
Tel: 630-285-0071
Fax: 630-285-0075

Dallas

16200 Addison Road, Suite 255
Addison Plaza
Addison, TX 75001
Tel: 972-818-7423
Fax: 972-818-2924

Detroit

Tri-Atria Office Building
32255 Northwestern Highway, Suite 190
Farmington Hills, MI 48334
Tel: 248-538-2250
Fax: 248-538-2260

Kokomo

2767 S. Albright Road
Kokomo, IN 46902
Tel: 765-864-8360
Fax: 765-864-8387

Los Angeles

25950 Acero St., Suite 200
Mission Viejo, CA 92691
Tel: 949-462-9523
Fax: 949-462-9608

San Jose

1300 Terra Bella Avenue
Mountain View, CA 94043
Tel: 650-215-1444
Fax: 650-961-0286

Toronto

6285 Northam Drive, Suite 108
Mississauga, Ontario L4V 1X5, Canada
Tel: 905-673-0699
Fax: 905-673-6509

ASIA/PACIFIC

Australia

Microchip Technology Australia Pty Ltd
Unit 32 41 Rawson Street
Epping 2121, NSW
Sydney, Australia
Tel: 61-2-9868-6733
Fax: 61-2-9868-6755

China - Beijing

Unit 706B
Wan Tai Bei Hai Bldg.
No. 6 Chaoyangmen Bei Str.
Beijing, 100027, China
Tel: 86-10-85282100
Fax: 86-10-85282104

China - Chengdu

Rm. 2401-2402, 24th Floor,
Ming Xing Financial Tower
No. 88 TIDU Street
Chengdu 610016, China
Tel: 86-28-86766200
Fax: 86-28-86766599

China - Fuzhou

Unit 28F, World Trade Plaza
No. 71 Wusi Road
Fuzhou 350001, China
Tel: 86-591-7503506
Fax: 86-591-7503521

China - Hong Kong SAR

Unit 901-6, Tower 2, Metroplaza
223 Hing Fong Road
Kwai Fong, N.T., Hong Kong
Tel: 852-2401-1200
Fax: 852-2401-3431

China - Shanghai

Room 701, Bldg. B
Far East International Plaza
No. 317 Xian Xia Road
Shanghai, 200051
Tel: 86-21-6275-5700
Fax: 86-21-6275-5060

China - Shenzhen

Rm. 1812, 18/F, Building A, United Plaza
No. 5022 Binhe Road, Futian District
Shenzhen 518033, China
Tel: 86-755-82901380
Fax: 86-755-8295-1393

China - Shunde

Room 401, Hongjian Building, No. 2
Fengxiangnan Road, Ronggui Town, Shunde
District, Foshan City, Guangdong 528303, China
Tel: 86-757-28395507 Fax: 86-757-28395571

China - Qingdao

Rm. B505A, Fullhope Plaza,
No. 12 Hong Kong Central Rd.
Qingdao 266071, China
Tel: 86-532-5027355 Fax: 86-532-5027205

India

Divyasree Chambers
1 Floor, Wing A (A3/A4)
No. 11, O'Shaughnessy Road
Bangalore, 560 025, India
Tel: 91-80-22290061 Fax: 91-80-22290062

Japan

Yusen Shin Yokohama Building 10F
3-17-2, Shin Yokohama, Kohoku-ku,
Yokohama, Kanagawa, 222-0033, Japan
Tel: 81-45-471-6166 Fax: 81-45-471-6122

Korea

168-1, Youngbo Bldg. 3 Floor
Samsung-Dong, Kangnam-Ku
Seoul, Korea 135-882
Tel: 82-2-554-7200 Fax: 82-2-558-5932 or
82-2-558-5934

Singapore

200 Middle Road
#07-02 Prime Centre
Singapore, 188980
Tel: 65-6334-8870 Fax: 65-6334-8850

Taiwan

Kaohsiung Branch
30F - 1 No. 8
Min Chuan 2nd Road
Kaohsiung 806, Taiwan
Tel: 886-7-536-4816
Fax: 886-7-536-4817

Taiwan

Taiwan Branch
11F-3, No. 207
Tung Hua North Road
Taipei, 105, Taiwan
Tel: 886-2-2717-7175 Fax: 886-2-2545-0139

Taiwan

Taiwan Branch
13F-3, No. 295, Sec. 2, Kung Fu Road
Hsinchu City 300, Taiwan
Tel: 886-3-572-9526
Fax: 886-3-572-6459

EUROPE

Austria

Durisolstrasse 2
A-4600 Wels
Austria
Tel: 43-7242-2244-399
Fax: 43-7242-2244-393

Denmark

Regus Business Centre
Lautrup hoj 1-3
Ballerup DK-2750 Denmark
Tel: 45-4420-9895 Fax: 45-4420-9910

France

Parc d'Activite du Moulin de Massy
43 Rue du Saule Trapu
Batiment A - ler Etage
91300 Massy, France
Tel: 33-1-69-53-63-20
Fax: 33-1-69-30-90-79

Germany

Steinheilstrasse 10
D-85737 Ismaning, Germany
Tel: 49-89-627-144-0
Fax: 49-89-627-144-44

Italy

Via Salvatore Quasimodo, 12
20025 Legnano (MI)
Milan, Italy
Tel: 39-0331-742611
Fax: 39-0331-466781

Netherlands

Waegenburghtplein 4
NL-5152 JR, Drunen, Netherlands
Tel: 31-416-690399
Fax: 31-416-690340

United Kingdom

505 Eskdale Road
Winnersh Triangle
Wokingham
Berkshire, England RG41 5TU
Tel: 44-118-921-5869
Fax: 44-118-921-5820

07/12/04